



LNB

KA-BAND EXT. REF

9000XH



TYPICAL SPECIFICATIONS

Noise figure	1.3 dB
L.O. stability	Phase locked to External Reference
Phase noise (SSB) max	-63 dBc/Hz at 100Hz -80 dBc/Hz at 1kHz -92 dBc/Hz at 10kHz -100 dBc/Hz at 100kHz
Input VSWR	1.3 : 1
Output VSWR	1.44 : 1

Conversion gain	60 dB
Output P1dB	>3 dBm
Power requirements	+9 to +13 V supplied through center conductor of IF cable
Waveguide Flange	WR42
Current drain	400 mA
Dimensions	120 (L) x 45 (W) x 51(H) mm (2.0 x 1.8 x 3.9 in)
Weight	350g / 12.3 oz
Temperature Range	-30°C to +55°C
Input Stability	Unconditionally Stable
Gain Flatness	2.5 dB p-p over Full Band
Gain Variation over Temp	±2 dB
External Reference	10 MHz, -3 to +3 dBm
Desensitization	-25 dBm (30 - 31 GHz)
Max Input no damage	0 dBm (20.2 - 21.2 GHz) +10 dBm (30-31 GHz)
Comply to MIL STD	MIL - STD - 188 - 164

FREQUENCY BANDS AVAILABLE

Typical service	9000XH	
Input frequency (GHz)	20.20 to 21.20	
L.O. frequency (GHz)	L: 19.25	H: 19.20
Output frequency (MHz)	L: 950 to 1950	H: 1000 to 2000

HOW TO ORDER KA-BAND 9000XH

9000XH CN1-W3

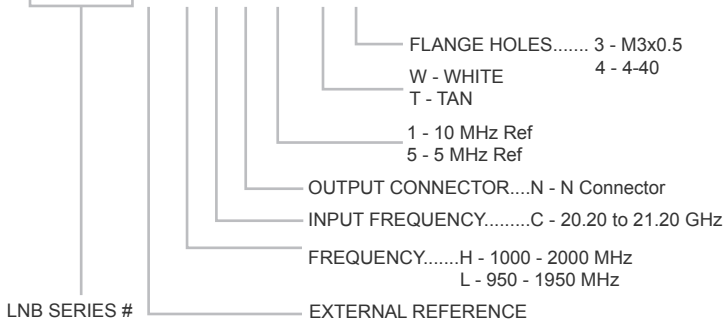

MECHANICAL DIAGRAM

